

Oilgear

INTRODUCTION TO CARTRIDGE VALVES

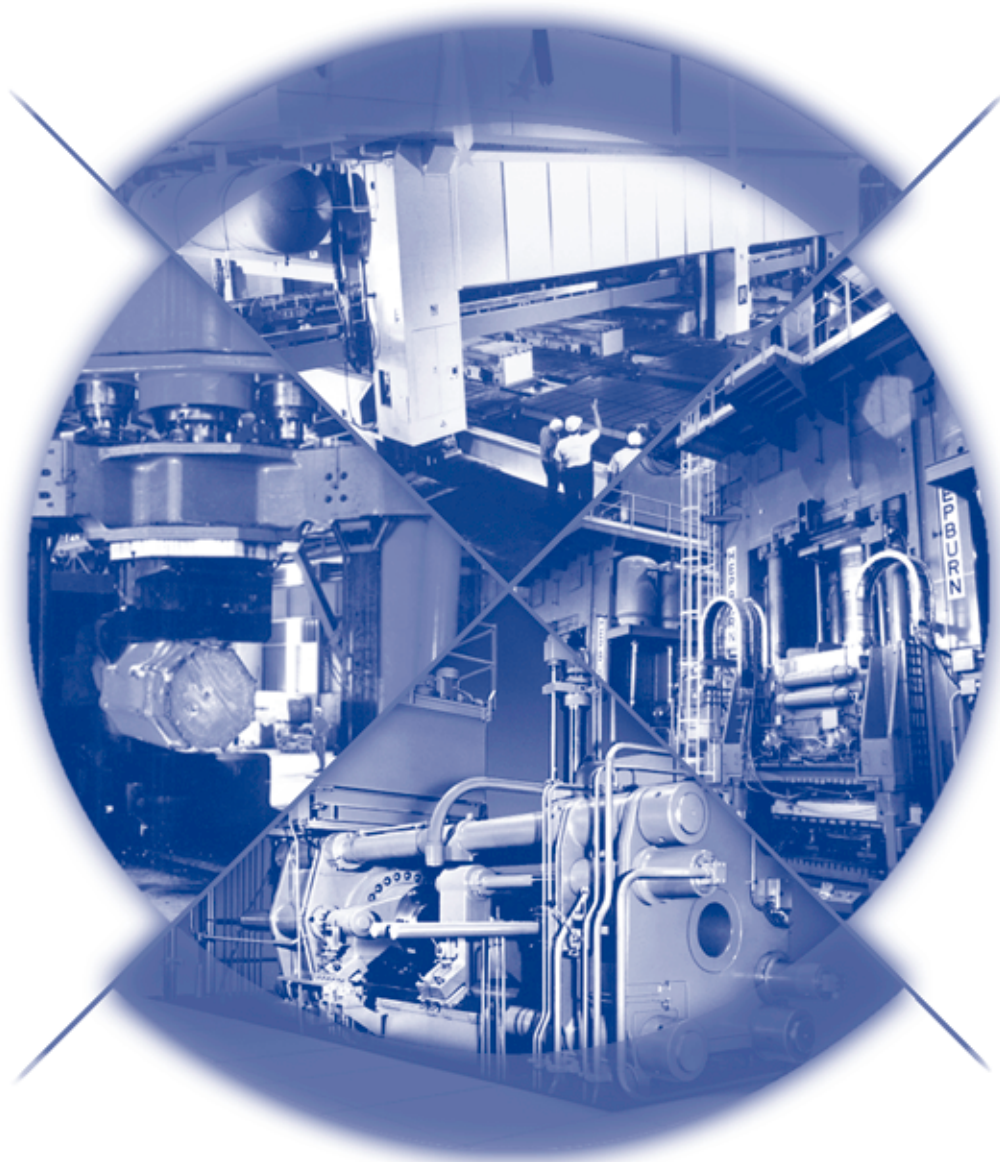

System Solutions Guide



Oilgear

The cartridge valve,

with nearly 30 years of successful applications experience, holds a unique position in the fluid power industry. Its small size, fast switching speeds, and cost effective design, make it an integral part of many motion control and fluid power systems. Oilgear's extensive experience in the application of cartridge valve technology allows us to offer one of the most complete line of cartridge valves, ranging in sizes from 16 to 160, as per DIN standard 24342 for sizes 16 to 100. In addition to our standard cartridge valves, Oilgear also offers a complete line of high flow and active cartridge valves for more specialized and higher performance fluid power systems.

The combination of different Oilgear cartridge valves, cover plates and if necessary pilot valves, can lead to configurations that replicate check, directional, pressure, and flow control device functionality. Individual Oilgear cartridge valve catalogs illustrate how cartridge valves and cover plates can be combined to produce different functions, and present the entire product offering in a way to make ordering easy.



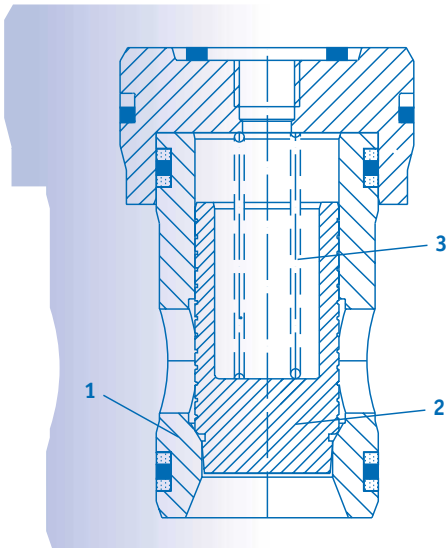

Cartridge valves

consist basically of a sleeve (1), valve poppet or cone (2), and closing spring (3).

The cartridge assembly is designed to fit within a cavity defined by DIN 24342, is held in place and sealed by a cover.

The manifold block acts as the valve housing and contains ports A and B together with the pilot control lines.

The control cover contains the pilot control drillings, thus also acts as the connection to the pilot side of the cartridge valve (spring side and the connection X).

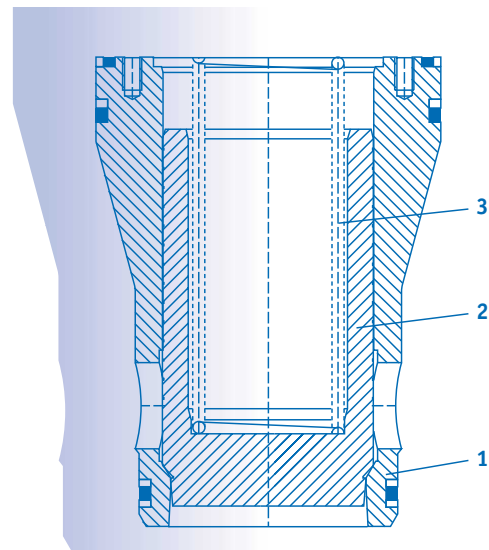

Introduction to Cartridge Valves	2-3
How Cartridge Valves Work	4-5
Application	6
Comparative Advantages	7
Create Single Valve Functionality	8
Product Line	9-10
Unique Benefits	11

Cartridge valves

also known as 2/2-way valves or logic valves, have two operational ports A and B. The flow path between these two connections is controlled hydraulically by pilot pressure applied through port X. The basic cartridge valve includes a valve poppet which is normally held in the closed position by a spring. The poppet valve has a seated cone, giving a near zero leakage (dependent upon pilot control) condition across the two ports. The closing spring is retained by the control cover which encloses the cartridge valve and provides pilot connections from the X port. Various types of pilot control can be mounted either to the control cover or to an adjacent manifold face, to provide direct control of the cartridge valve.

The effective areas of the basic element are A_A , A_B and A_x . Pilot fluid can be taken from port A, B or both A and B (with a shuttle valve), or an external source. Hydraulic fluid can flow through the 2-way cartridge valve from $A \rightarrow B$ or $B \rightarrow A$.

If a pilot valve is used, it can directly control the switching function of the cartridge valve,

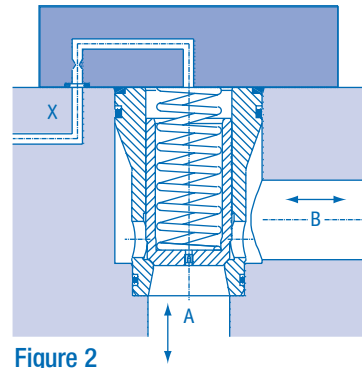

either between two extreme positions, open or closed, or in any number of intermediate positions. The exact position of the valve cone depends on the ratio of control surface A_x to the pressures acting from the working connections A and B on the seating surface of A_A and the annular area of A_B . (See Figure 3)

If the valve cone is open, by reducing the pressure seen at X, then flow can move from A and B or vice-versa. By applying a control pressure at X, the working connections A to B are shut off as the valve cone is closed by the seat mounting. If there is a pressure difference between connection B and pilot connection X as a result of clearance tolerance between the cone and sleeve, then leakage can be eliminated

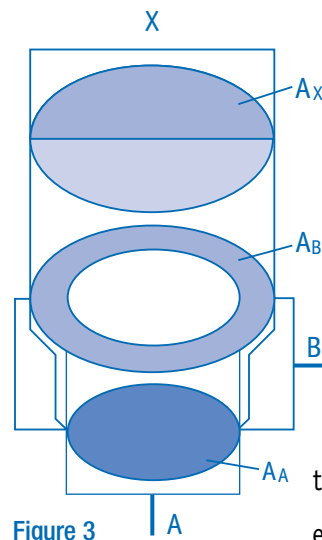
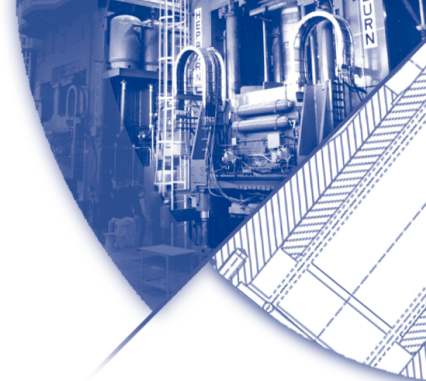
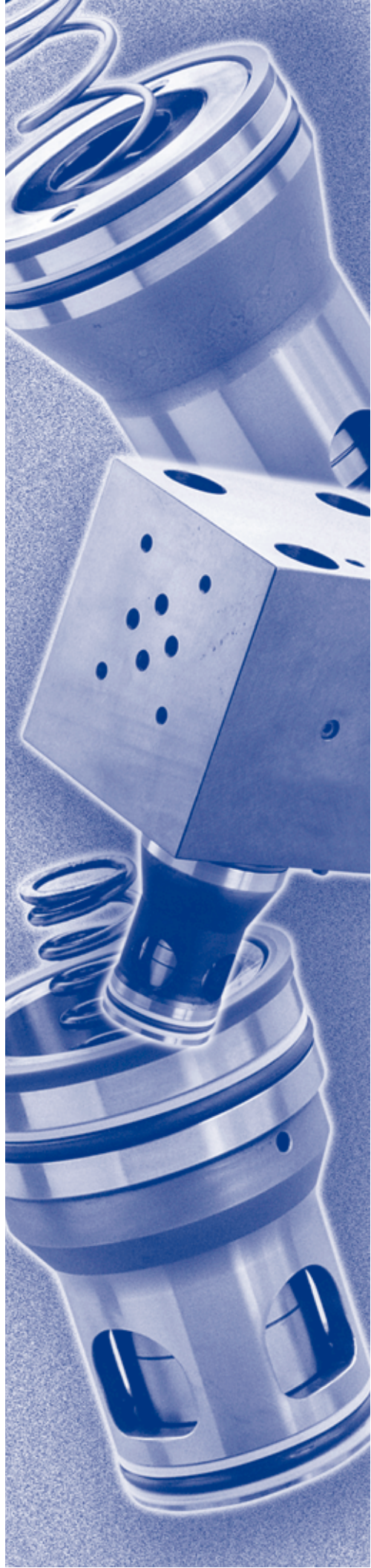

Figure 3

by using a leakproof seat valve and hooking up the pilot connection X to the working connection B. If the desired function does not permit such a switching operation, a cartridge valve with an additional sealing surface can be used to seal the connections A, B and X from each other.



The Operation of Logic Elements is Always Purely Pressure Dependent

The three areas which are important for the functioning of a cartridge valve are:

- The area of the valve seat A_A .
- The annulus area at port B (A_B).
- The area on the spring side A_x , which is the sum of the areas A_A and A_B .
- The ratio of A_A to A_x is normally 1:1.6 for standard cartridge valves and 1:2 for high flow valves.

The Following is then Valid:

Areas A_A and A_B operate in the opening direction. Area A_x and the spring have a closing effect on the valve. The summation of the opening and closing forces determines whether the logic element will open or close. When no pressure is applied to the valve, the poppet sits on its seat. By applying pressure to area A_x usually from port A, or port B, or A and B via a shuttle valve, the valve poppet can allow a free connection A to B.

- Closing forces
 $P_x \bullet A_x + \text{spring force}$
- Opening forces
 $P_A \bullet A_A +$
 $P_B \bullet A_B$

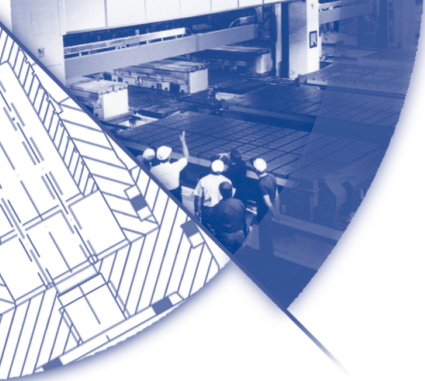

Application

Again, cartridge valves have two working connections A and B where the main flow is hydraulically operated by a controlling pressure applied at connection X.

Depending on the control input, these valves can be used as:

- Directional control valves
(start, stop, directional control)
- Pressure control valves
(pressure relief, pressure control, pressure sequence and unloading function)
- Check valves
(check valve function and pilot operated check valve function)
- Flow control valves

The preferred mode of mounting is in a manifold block, which can be equipped with several valves depending on the hydraulic circuit for the specific application. Valves are connected to each other in the manifold block.

The Oilgear product line contains valves of nominal bores sizes: 16, 25, 32, 40, 50, 63, 80 and 100 as per DIN 24342 for flows up to 2640 gpm (10,000 l/min.), and sizes 125, 160 up to 6340 gpm (24,000 l/min.) with cover plates and pilot valves for various functions.

In addition to this, our product offering also contains individual cartridge housings for a great number of applications, that can be subplate, pipe and flange mounted.

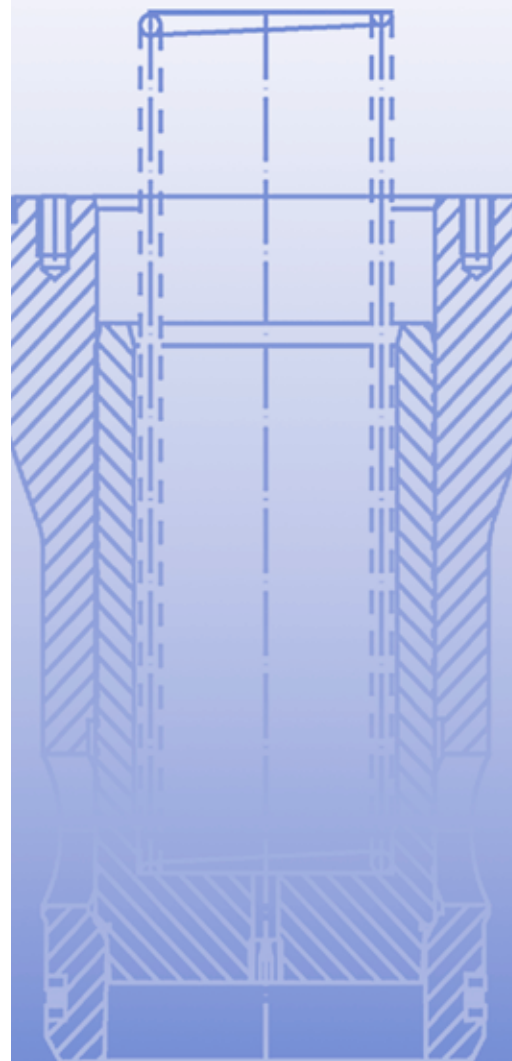

A



Figure 4

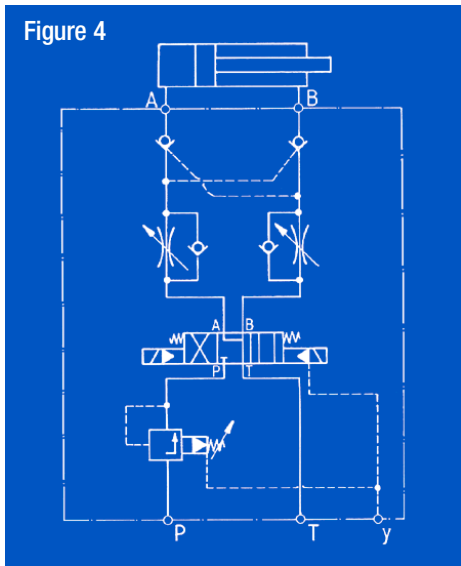

Conventional Control with Single Function Valves

In a conventional hydraulic system, the system's functionality is achieved by connecting single function valves in a parallel or series fashion. The inclusion of flow, directional, pressure or check control single function valves results in a system which requires more valves, more space, greater system losses and increased weight. (See Figure 4).

Cartridge Valve Control

Since cartridge valves can be utilized to replicate the functionality of flow, pressure, directional and check control, a system comprised of cartridge valves mounted in a manifold block can be designed to reproduce the functionality of the conventional hydraulic system. The valve functionality can be relocated from the working circuit to the control circuit, thereby simplifying the circuit complexity. Furthermore, the number of space intensive single function valves is reduced, or eliminated outright, creating a space savings. Lastly, the pressure drop across a cartridge valve is often less than a corresponding single function valve, resulting in a reduction of system losses. (See Figure 5).

Features

- Increased power density
- Several functions at one mounting position
- Fast switching times
- Mounting within a manifold
- Soft switching
- Single contact point within valve
- Large flow range
- Low pressure drop
- Higher permissible operating pressures (up to 5,000 psi)
- Low sensitivity to contamination
- Unlimited holding time and special safety certifications
- Insensitive to water based fluids
- Insensitive to high pressure drops

Benefits

- Smaller system size
- Reduced system cost
- Enhanced system response
- Reduced chance of fluid leakage
- Fewer system pressure spikes
- Improved component life
- More cost effective control in high flow systems
- Reduced energy consumption
- More cost effective control
- Longer field life without maintenance
- Ideal for safety circuits
- Greater stability across all operating conditions
- Can be used in super high flow systems and hazardous environments

Figure 5

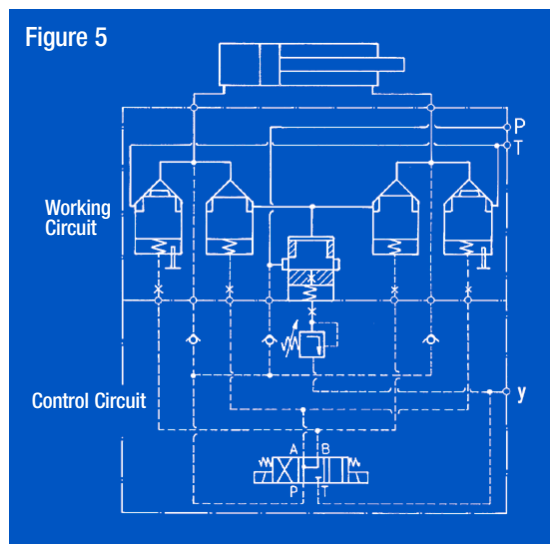

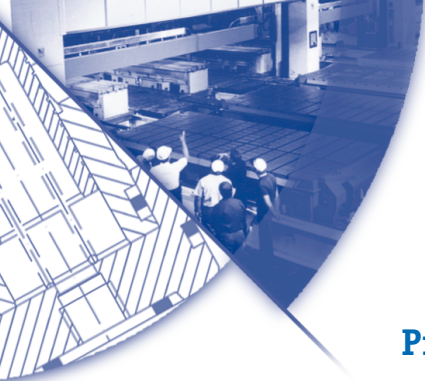

Pressure Control Valves

To reproduce the functionality of a pressure control valve, the cartridge valve is usually utilized as a main stage; therefore, the control surface area A_x and the cone surface area A_A should correspond to a ratio of 1:1 for an optimized function.

This is guaranteed by a cartridge valve with cone A and the matching sleeve A. Note, however, that there can only be a flow from A to B in this cartridge valve.

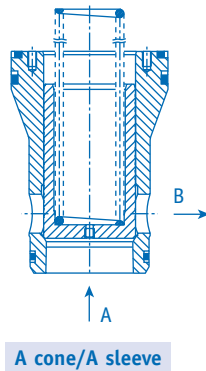

In order to improve the control reaction within the same range, a cartridge cone with a dampening nose can be used. Accordingly, the cartridge is then composed of a sleeve A and a cone D with a cone ratio of 1:1.

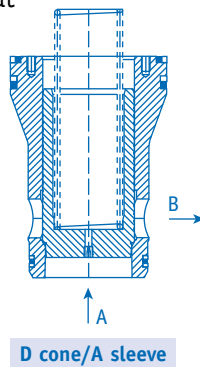

Again, the flow direction is only from A to B.

Directional Control Valves, Check Valves and Flow Control Valves

A cartridge valve which permits flows in either direction ($A \leftrightarrow B$), is required for directional control, check, and flow control valve applications. In these situations, cones with a control surface area A_x that is larger than the cone surface A_A ($A_x > A_A$) must be used, therefore, the cone surface area A_B must not be 0.

For directional control, check, and flow control applications, a cartridge with a sleeve B and cone B is specified. Soft switching operations are the result of the difference between control surface area A_x and cone surface A_A .

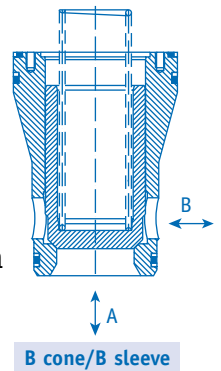

In order to avoid pressure peaks in tank circuits, or to better adjust flow control valves, the cone B can be replaced by a cone with a dampening nose such as cone C.

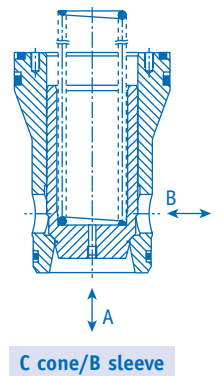

Check Valves

If a cartridge valve is to be used as a check valve, the control surface area A_x must be bigger than the cone surface area A_A .

A special cone R makes it possible to minimize the installation effort of

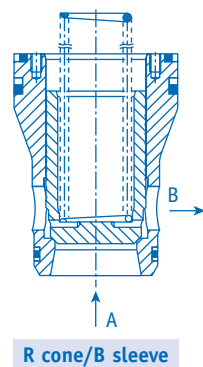

the check valve function in the control unit, by eliminating the need for additional control drillings and special cartridge covers. A cartridge valve comprised of sleeve B and cone R flows freely from A to B and completely shuts off flow from B to A.

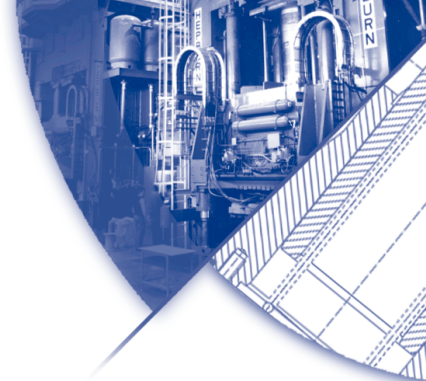

The Oilgear Cartridge Valve Product Line

Oilgear cartridge valve product line consists of three types of valves:

- Standard cartridge valves
- High flow cartridge valves
- Active cartridge valves

The chart below illustrates the flow ranges that delineate our standard and high flow lines.

Standard and High Flow Valve Flow Rates

Flow at 90 psi drop (6 bar)

SIZE	STANDARD		HIGH FLOW	
NB16	53 gpm	(200 lpm)	86 gpm	(325 lpm)
NB25	120 gpm	(450 lpm)	178 gpm	(675 lpm)
NB32	225 gpm	(850 lpm)	290 gpm	(1,100 lpm)
NB40	400 gpm	(1,500 lpm)	422 gpm	(1,600 lpm)
NB50	800 gpm	(3,000 lpm)	925 gpm	(3,500 lpm)
NB63	1,200 gpm	(4,500 lpm)	1,385 gpm	(5,250 lpm)
NB80	1,850 gpm	(7,000 lpm)	2,180 gpm	(8,250 lpm)
NB100	2,640 gpm	(10,000 lpm)	3,350 gpm	(12,700 lpm)
NB125	3,700 gpm	(14,000 lpm)		
NB160	6,340 gpm	(24,000 lpm)		

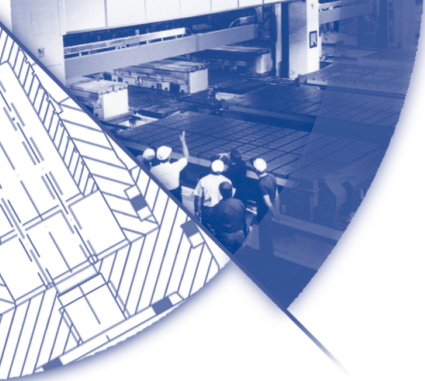

Oilgear active cartridge valves are a separate line of product based on our standard valve, but offers enhanced levels of control. Oilgear active cartridges were designed to address the limitation of standard cartridges—closing time, opening time, tightness, prefill valve function, control pressure, closing under load, and lack of feedback.

Our active cartridge valves include an additional control area, which provides enhanced control of switching forces. This enhanced level of control is critical for higher speed or faster response applications, where low system pressure can delay the closing process.

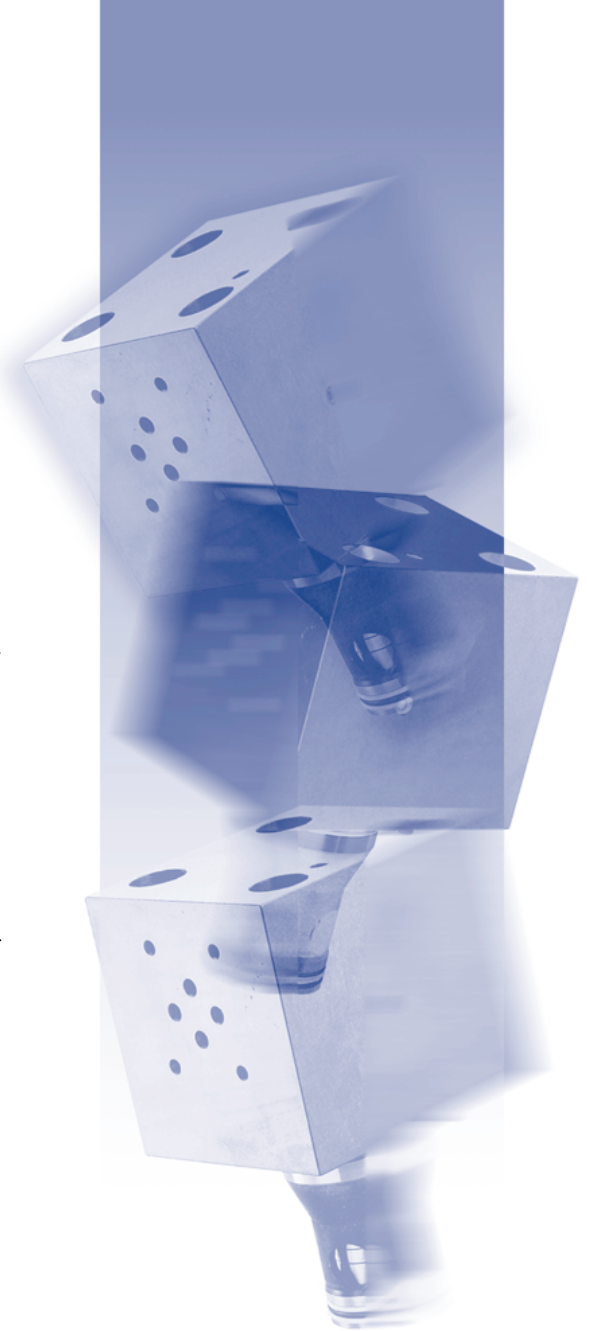

Standard Cartridge

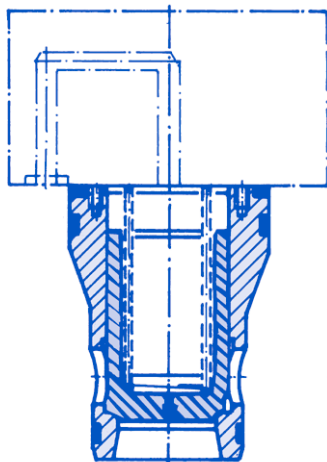

Active Cartridge

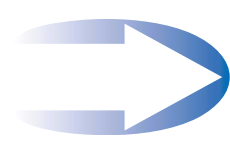
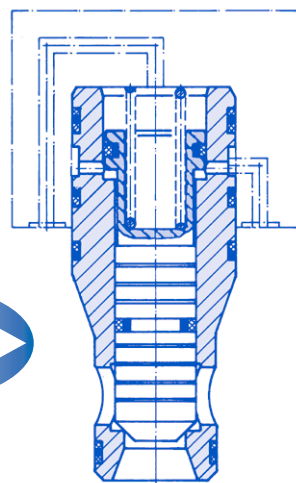

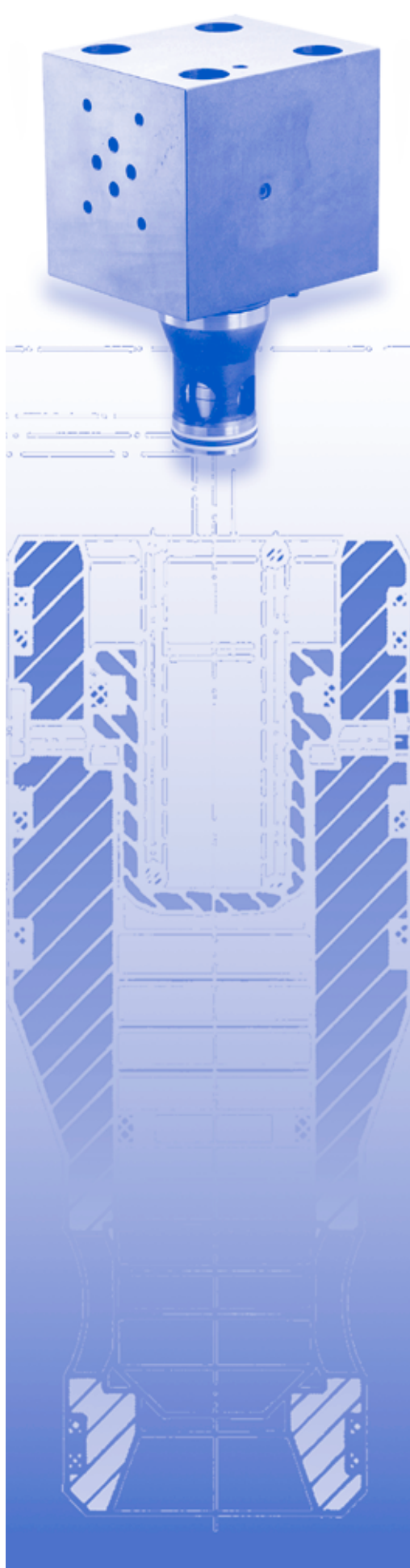

The Primary Benefits of Oilgear Active Cartridge Valves are:

- Large flow range
- Compact installation dimension
- Short operational times
- Minimal pressure peaks
- High functional reliability

Furthermore, Oilgear active cartridge valves can perform a prefill function, something traditional cartridges cannot.

In conclusion, Oilgear proudly offers to you our most complete line of cartridge valves yet. We present the details of each of our cartridge valves – standard flow, high flow and active – in a series of separate brochures. Each valve is profiled in its own brochure, with product options consisting of:

- Size
- Cone and sleeve configuration
- Cover type
- Orifice

Oilgear Unique Benefits

Oilgear

World Headquarters The Oilgear Company

2300 South 51st Street Milwaukee, WI USA 53219
phone: 414/327-1700 fax: 414/327-0532

www.oilgear.com

For more information about your application or the products in this brochure, please contact your nearest Oilgear facility.

Performance Assurance

Each Oilgear component manufactured is shipped with corporate commitment to stay with the installation until the unit performs as specified.

This total dedication to performance is based upon experience gained since 1921 in matching fluid power systems to a tremendous range of machines and applications.

Oilgear's Performance Assurance is made possible because of the many hydraulic techniques learned over the years in supplying machinery builders and users with unique solutions to hundreds of unusual fluid power problems.



Historically, Oilgear has concentrated its energies on hydraulic equipment and systems. Every Oilgear facility is staffed with factory trained and field experienced application engineers.

Performance Assurance doesn't stop with the design of the system or the sale of the component. Oilgear engineers will be there — when they are needed, where they are needed — supplying the technical support, field service, parts and repairs to make sure each component operates correctly.

AUSTRALIA

Oilgear Towler Australia Pty. Ltd.

BRAZIL

Oilgeardo Brazil Hydraulica Ltd.

CANADA

The Oilgear Company

FRANCE

Oilgear Towler S.A.

GERMANY

Oilgear Towler GmbH

INDIA

Oilgear Towler Polyhydron Pvt. Ltd.
Towler Automation Pvt. Ltd.

ITALY

Oilgear Towler S.r.l.

JAPAN

The Oilgear Japan Company

KOREA

Oilgear Towler Korea Co. Ltd.

MEXICO

Oilgear Mexicana S.A. de C.V.

SPAIN

Oilgear Towler S.A.

TAIWAN

Oilgear Towler Taiwan Co. Ltd.

UNITED KINGDOM

Oilgear Towler Ltd.

UNITED STATES OF AMERICA

The Oilgear Company

